

# DRC Core

1. Shape 形狀

Fig 1

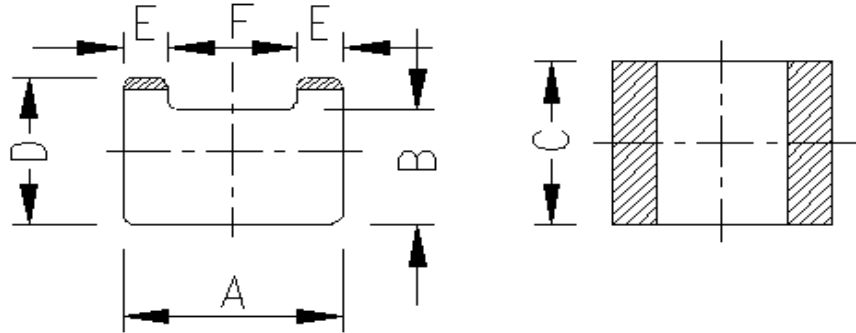

2. Ordering Code 編碼規則

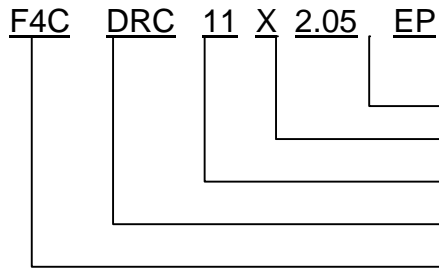

- Electroplating 電鍍
- D = Height 高度
- A = Length 長度
- Core Type 型式
- Material 材質

3. Dimensions 尺寸 ( mm )

Core Size \ Conf.	A	B	C	D	E	F	Fig
DRC 1.6x0.8 EP	1.6±0.1	0.58±0.1	0.8±0.1	0.8±0.1	0.33	0.94	1
DRC 2.0x1.2 EP	2.0±0.1	0.7±0.1	1.2±0.1	1.2±0.1	0.50	1.00	1
DRC 2.5x1.8 EP	2.5±0.1	1.4±0.1	2.0±0.1	1.8±0.1	0.50	1.50	1
DRC 11.0x2.6 EP	11.0±0.4	1.9±0.15	2.0±0.15	2.6±0.15	1.00	9.00	1